

A	B	C	D	E	F	G	H	L	J	K	L
							REV. 1-ALTER. TUBO UNIÃO ALT-DM-0010/2009				
							REV. 2-ALTER. GEOMETRIA FLANGES DO TRANSMISSOR - ALT-DD-0016/2010				
							REV. 3-ALTER. TITULO E GEOMETRIA FLANGES - ALT-0440/14				
							REV. 4-ACRESC NOTAS E TITULO EM INGLES - ALT-0821/2021				

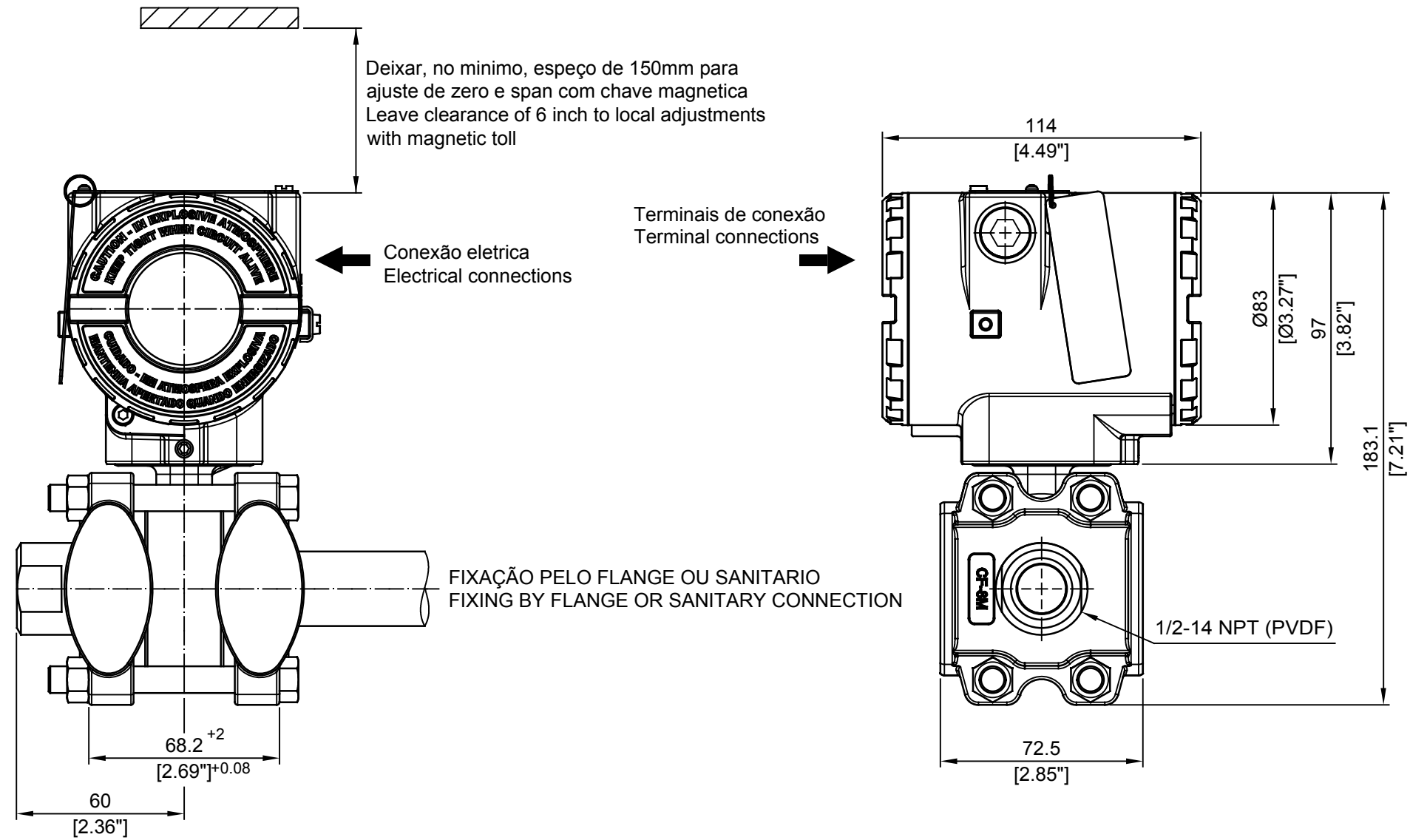

NOTAS/NOTES:
 AS DIMENSÕES SÃO EM mm (POLEGADAS)
 MONTAGEM LIMITADA A 24BAR (KYNAR)
 DIMENSIONS ARE IN mm (INCH)
 ASSEMBLY LIMITED TO 24BAR (KYNAR)

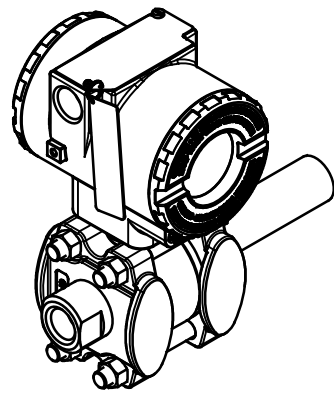

4	GUSKA 03 / 05 / 2021	P.MISAWA 03 / 05 / 2021	GERAL	DESENHO	PROJETO	VERIFIC.	APROVAÇÃO	smar
3	GUSKA 26 / 08 / 2014	P.MISAWA 11 / 03 / 2015	GERAL	EDNA 25 / 04 / 2006	EDNA 25 / 04 / 2006	GUSKA 25 / 04 / 2006	P.MISAWA 25 / 04 / 2006	
2	GUSKA 05 / 04 / 2010	P.MISAWA 05 / 04 / 2010	GERAL	CLIENTE				OS
1	GUSKA 03 / 07 / 2009	IVAN 03 / 07 / 2009	D-5	EQUIPAMENTO LD300 SERIES				DESENHO N°
REV	PROJETO	APROVAÇÃO	AREA	DIMENSIONAL LD30XL REF KYNAR 1/2NPT LD30XL LOW KYNAR 1/2NPT				101-B-5389-03
								ESC 1:2 FL /